

NOT YOUR TYPICAL SPILLAGE

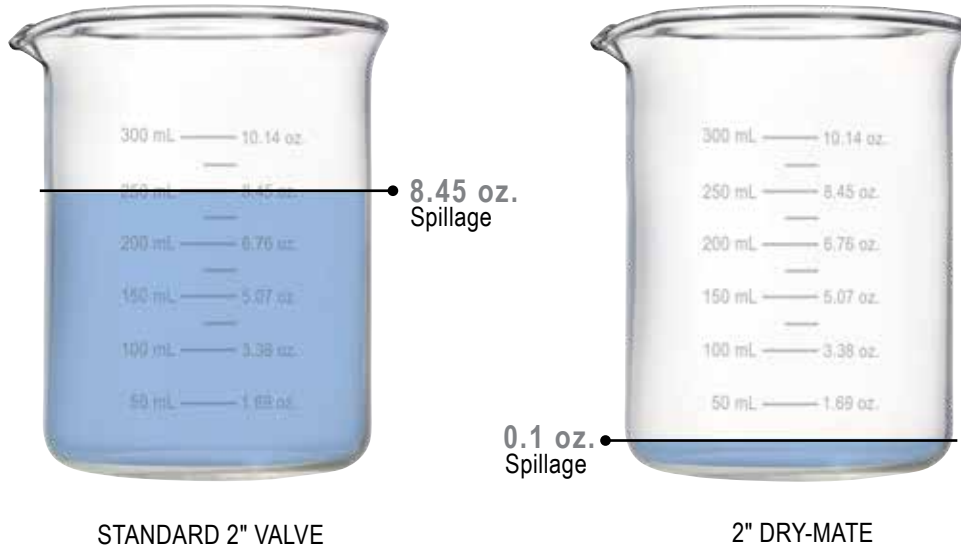

99% SPILLAGE REDUCTION

- Reduction of typical spillage using standard 2" valve with cam lock connection vs. Dry-Mate
- 8.45 oz. (250 mL) vs. 0.1 oz. (3 mL) spillage
- At five disconnections per day, this is **over 118 gallons (450 liters) saved per year**; enough to fill the gas tanks of eight mid-size automobiles

FEATURES



SAFETY FIRST

Product is important, but the safety of your team is essential. With Dry-Mate Dry-Disconnects, leakage from disconnecting is miniscule compared to standard valves. When properly installed and operated, the danger posed by harmful chemicals contacting your team is greatly reduced.



EVERY DROP COUNTS

Your product is money. Why waste money in spilling your product every time you disconnect? With Dry-Mate, your spillage amount will be significantly reduced. At 3 mL product spillage for a 2" line, you can have peace of mind that your product is being placed where it should be and not on the ground.



PRODUCT ONLY WHERE YOU WANT IT

When a Dry-Mate is properly installed and operated, the assembly will not accidentally separate while fluid is flowing; preventing costly mishaps.



DITCH THE MAINTENANCE

All that spillage has to go somewhere. If you are collecting large areas of spillage run-off, you have to have it pumped out. Reduce your maintenance costs on your spillage pits by keeping fluids contained.

DRY-MATES

1½" POLY DRY-MATES

FEATURES

- Lightweight
- Easy to use
- Economical
- Reduces risk of exposure
- Wide range of chemical resistance
- Unrestricted 1½" flow
- Patented double ball design with cam lever connection
- When properly installed and operated, the assembly will not accidentally separate while fluid is flowing; preventing costly mishaps
- Spillage data: 1½" = 2ml



REPAIR KIT INCLUDES:

- Ball
- Body gasket
- Thrust washer
- Ball seats
- Upper stem bushing
- Stem o-ring

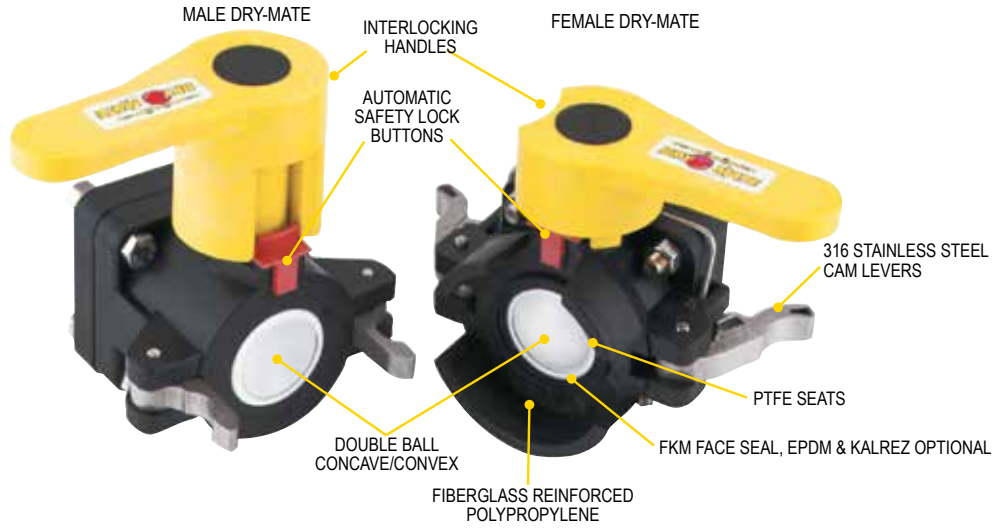

1½" POLY MALE DRY-MATE

| PART NO | DESCRIPTION | MAX PSI | PIPE SIZE | OPENING THRU BALL | QTY |
|---------|--------------------------------|---------|-----------|-------------------|-----|
| DM150A | 1½" MALE X FPT NPT W/FKM SEALS | 100 | 1½" | 1½" | 1 |
| DM150AB | 1½" MALE X FPT BSP W/FKM SEALS | 100 | 1½" | 1½" | 1 |

1½" POLY FEMALE DRY-MATE

| PART NO | DESCRIPTION | MAX PSI | PIPE SIZE | OPENING THRU BALL | QTY |
|---------|----------------------------------|---------|-----------|-------------------|-----|
| DM150D | 1½" FEMALE X FPT NPT W/FKM SEALS | 100 | 1½" | 1½" | 1 |
| DM150DB | 1½" FEMALE X FPT BSP W/FKM SEALS | 100 | 1½" | 1½" | 1 |

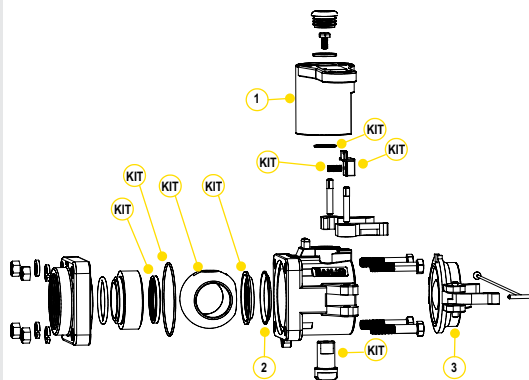

REPLACEMENT PARTS MALE

| ITEM | PART NO | DESCRIPTION | QTY |
|------|----------|-----------------------|-----|
| 1 | DM20153M | MALE HANDLE | 1 |
| 1 | DB20153M | LOW PROFILE HANDLE | 1 |
| 2 | DB20290 | FKM FACE SEAL | 1 |
| 2 | DB20295 | EPDM FACE SEAL | 1 |
| 2 | DM20296 | KALREZ® FACE SEAL | 1 |
| 3 | DM200CAP | DUST CAP | 1 |
| KIT | DM20200A | REPAIR KIT FOR DM150A | 1 |

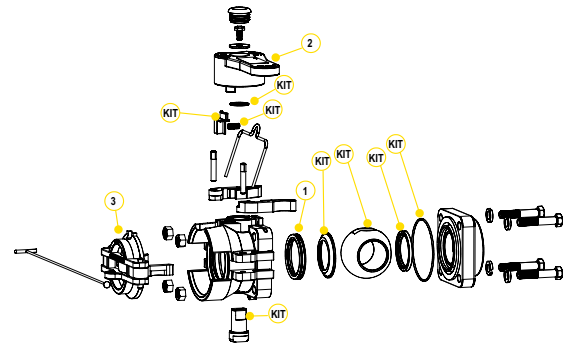

REPLACEMENT PARTS FEMALE

| ITEM | PART NO | DESCRIPTION | QTY |
|------|----------|-----------------------|-----|
| 1 | DM20294A | FKM FACE SEAL | 1 |
| 1 | DB20295A | EPDM FACE SEAL | 1 |
| 1 | DM20296 | KALREZ® FACE SEAL | 1 |
| 2 | DM20153F | FEMALE HANDLE | 1 |
| 3 | DM200PL | DUST PLUG | 1 |
| KIT | DM20200D | REPAIR KIT FOR DM150D | 1 |



2" POLY DRY-MATES

FEATURES

- Lightweight
- Easy to use
- Economical
- Reduces risk of exposure
- Wide range of chemical resistance
- Unrestricted 1½" flow
- Patented double ball design with cam lever connection
- When properly installed and operated, the assembly will not accidentally separate while fluid is flowing; preventing costly mishaps
- Spillage data: 2" = 2.6ml

2" POLY MALE DRY-MATE

| PART NO | DESCRIPTION | MAX PSI | PIPE SIZE | OPENING THRU BALL | QTY |
|----------|---|---------|-----------|-------------------|-----|
| DM200A | 2" MALE X FPT NPT W/FKM SEALS | 100 | 2" | 1½" | 1 |
| DM200AB | 2" MALE X FPT BSP W/FKM SEALS | 100 | 2" | 1½" | 1 |
| DM200AE | 2" MALE X FPT NPT W/EPDM SEALS | 100 | 2" | 1½" | 1 |
| DMMT201A | 2" MALE X MALE NPT W/LOW PROFILE HANDLE | 100 | 2" | 1½" | 1 |

2" POLY FEMALE DRY-MATE

| PART NO | DESCRIPTION | MAX PSI | PIPE SIZE | OPENING THRU BALL | QTY |
|---------|---------------------------------|---------|-----------|-------------------|-----|
| DM200D | 2" FEMALE X FPT NPT W/FKM SEALS | 100 | 2" | 1½" | 1 |
| DM200DB | 2" FEMALE X FPT BSP W/FKM SEALS | 100 | 2" | 1½" | 1 |
| DM200DE | 2" FEMALE W/EPDM SEALS | 100 | 2" | 1½" | 1 |



REPAIR KIT INCLUDES:

- Ball
- Body gasket
- Thrust washer
- Ball seats
- Upper stem bushing
- Stem o-ring

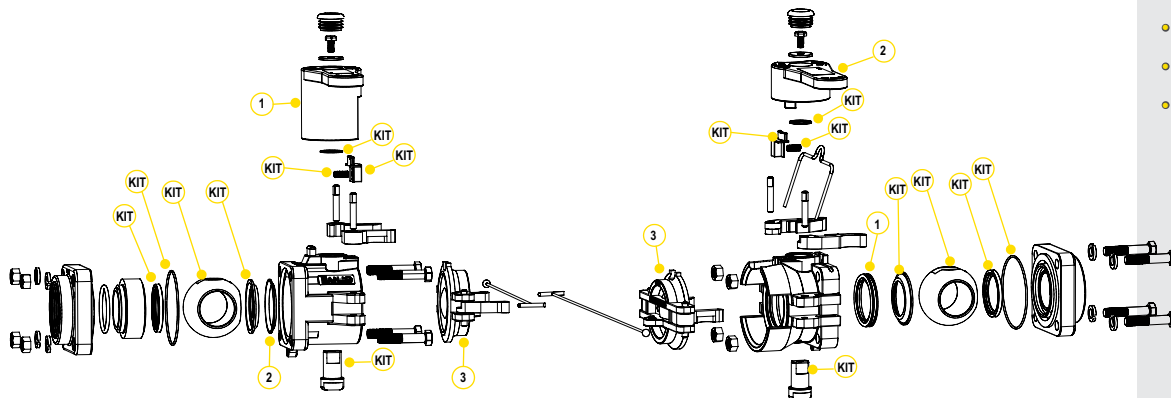

REPLACEMENT PARTS MALE

| ITEM | PART NO | DESCRIPTION | QTY |
|------|----------|---------------------------------|-----|
| 1 | DM20153M | MALE HANDLE | 1 |
| 1 | DB20153M | LOW PROFILE HANDLE | 1 |
| 2 | DB20290 | FKM FACE SEAL | 1 |
| 2 | DB20295 | EPDM FACE SEAL | 1 |
| 2 | DM20296 | KALREZ® FACE SEAL | 1 |
| 3 | DM200CAP | DUST CAP | 1 |
| KIT | DM20200A | REPAIR KIT FOR DM200A & DM200AE | 1 |

REPLACEMENT PARTS FEMALE

| ITEM | PART NO | DESCRIPTION | QTY |
|------|----------|---------------------------------|-----|
| 1 | DM20294A | FKM FACE SEAL | 1 |
| 1 | DB20295A | EPDM FACE SEAL | 1 |
| 1 | DM20296 | KALREZ® FACE SEAL | 1 |
| 2 | DM20153F | FEMALE HANDLE | 1 |
| 3 | DM200PL | DUST PLUG | 1 |
| KIT | DM20200D | REPAIR KIT FOR DM200D & DM200DE | 1 |

DRY-MATES

2" FULL PORT POLY DRY-MATES

FEATURES

- Lightweight
- Easy to use
- Economical
- Reduces risk of exposure
- Wide range of chemical resistance
- Unrestricted 2" flow
- Patented double ball design with cam lever connection
- When properly installed and operated, the assembly will not accidentally separate while fluid is flowing; preventing costly mishaps
- Spillage data: 2" FP = 3.6ml



DM220D

DM220A

2" FULL PORT POLY DRY-MATES

| PART NO | DESCRIPTION | MAX PSI | PIPE SIZE | OPENING THRU BALL | QTY |
|---------|---------------------------------|---------|-----------|-------------------|-----|
| DM220D | 2" FEMALE X FPT NPT W/FKM SEALS | 225 | 2" | 2" | 1 |
| DM220A | 2" MALE X FPT W/FKM SEALS | 225 | 2" | 2" | 1 |



REPAIR KIT INCLUDES:

- Body gasket
- Thrust washer
- Ball seats
- Upper stem bushing
- Stem o-ring
- Face seal

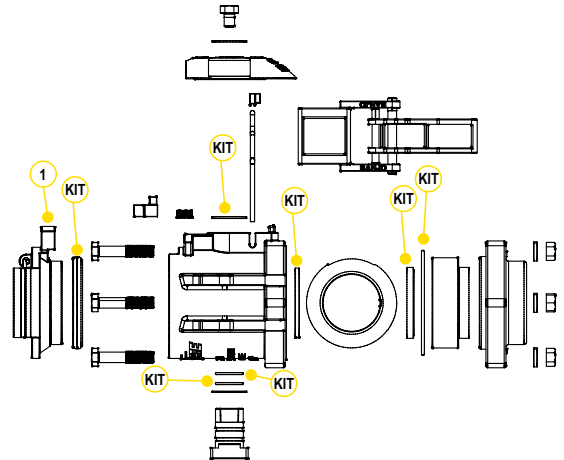
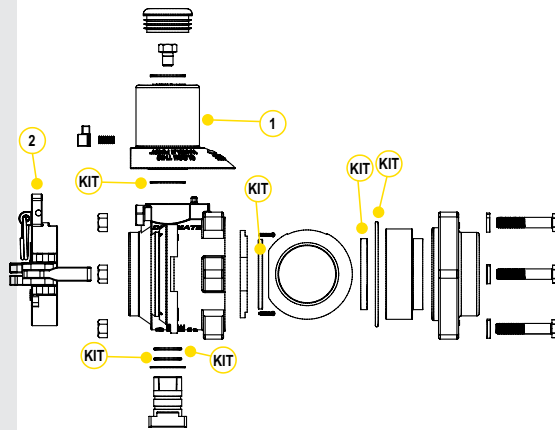

REPLACEMENT PARTS MALE

| ITEM | PART NO | DESCRIPTION | QTY |
|------|----------|-------------|-----|
| 1 | DM25153M | MALE HANDLE | 1 |
| 2 | DM220CAP | DUST CAP | 1 |
| KIT | DM25200 | REPAIR KIT | 1 |

REPLACEMENT PARTS FEMALE

| ITEM | PART NO | DESCRIPTION | QTY |
|------|---------|-------------|-----|
| 1 | DM221PL | DUST PLUG | 1 |
| 1 | DM25200 | REPAIR KIT | 1 |

3" FULL PORT POLY DRY-MATES

FEATURES

- Lightweight
- Easy to use
- Economical
- Reduces risk of exposure
- Wide range of chemical resistance
- Unrestricted 3" flow
- Patented double ball design with cam lever connection
- When properly installed and operated, the assembly will not accidentally separate while fluid is flowing; preventing costly mishaps
- Spillage data: 3" = 20ml



REPAIR KIT INCLUDES:

- Ball
- Body gasket
- Thrust washer
- Ball seats
- Upper stem bushing
- Stem o-ring
- Face seal



DM300DFP



DM300AFP

3" FULL PORT POLY DRY-MATES

| PART NO | DESCRIPTION | MAX PSI | PIPE SIZE | OPENING THRU BALL | QTY |
|----------|---|---------|-----------|-------------------|-----|
| DM300AFP | 3" FP MALE X 3" FEMALE NPT THREADS W/ FKM SEALS | 150 | 3" | 3" | 1 |
| DM300DFP | 3" FP FEMALE X 3" FEMALE NPT THREADS W/ FKM SEALS | 150 | 3" | 3" | 1 |

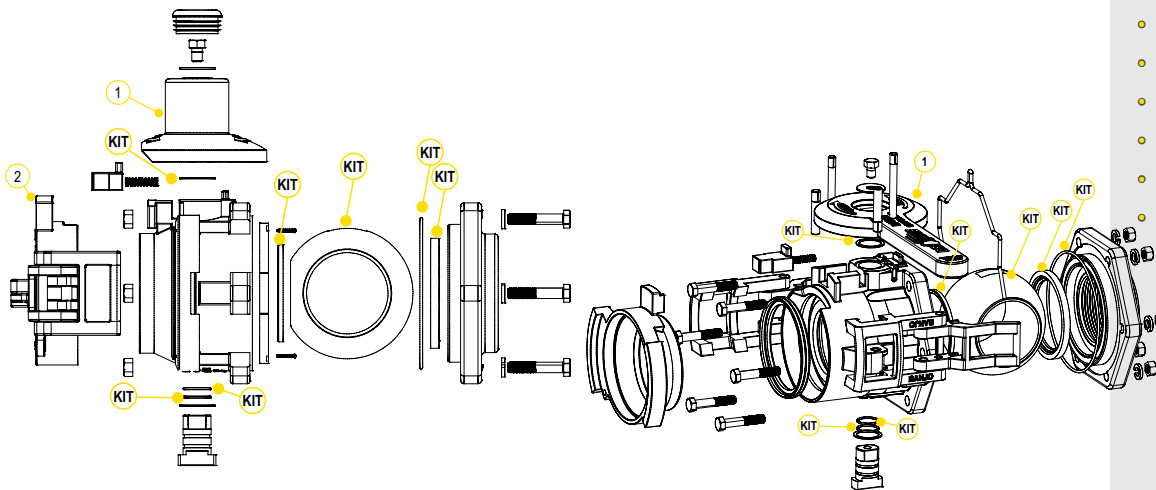

REPLACEMENT PARTS MALE

| ITEM | PART NO | DESCRIPTION | QTY |
|------|----------|-------------|-----|
| 1 | DM35153M | MALE HANDLE | 1 |
| 2 | DM300CAP | DUST CAP | 1 |
| KIT | DM35200 | REPAIR KIT | 1 |

REPLACEMENT PARTS FEMALE

| ITEM | PART NO | DESCRIPTION | QTY |
|------|----------|---------------|-----|
| 1 | DM35153F | FEMALE HANDLE | 1 |
| KIT | DM35200 | REPAIR KIT | 1 |

DRY-MATES

1" FULL PORT STAINLESS STEEL DRY-MATES

FEATURES

- 316 stainless steel construction
- Unrestricted 1" flow
- Patented double ball design with cam lever connection
- 300°F maximum operating temperature
- 100% PTFE ball seats
- When properly installed and operated, the assembly will not accidentally separate while fluid is flowing; preventing costly mishaps
- Spillage data: 1" FP = 1.7ml



DM100ASS

DM100DSS

1" FULL PORT STAINLESS STEEL DRY-MATE

| PART NO | DESCRIPTION | MAX PSI | PIPE SIZE | OPENING THRU BALL | QTY |
|-----------|-----------------------------------|---------|-----------|-------------------|-----|
| DM100ASS | 1" MALE X FPT NPT W/ PTFE SEALS | 150 | 1" | 1" | 1 |
| DM100ABSS | 1" MALE X FPT BSP W/ PTFE SEALS | 150 | 1" | 1" | 1 |
| DM100DSS | 1" FEMALE X FPT NPT W/ FKM SEALS | 150 | 1" | 1" | 1 |
| DM100DSSE | 1" FEMALE X FPT NPT W/ EPDM SEALS | 150 | 1" | 1" | 1 |
| DM100DBSS | 1" FEMALE X FPT BSP W/ FKM SEALS | 150 | 1" | 1" | 1 |



REPAIR KIT INCLUDES:

- Ball
- Body gasket
- Thrust washer
- Ball seats
- Upper stem bushing
- Stem o-ring
- Face seal

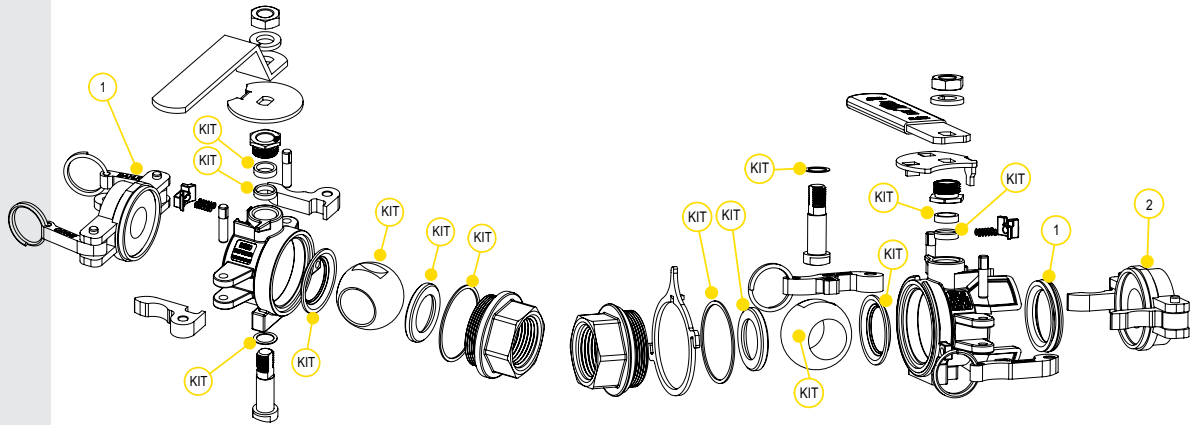

REPLACEMENT PARTS MALE

| ITEM | PART NO | DESCRIPTION | QTY |
|------|----------|-------------|-----|
| 1 | DM100CAP | DUST CAP | 1 |
| KIT | DM101SS | REPAIR KIT | 1 |

REPLACEMENT PARTS FEMALE

| ITEM | PART NO | DESCRIPTION | QTY |
|------|----------|-------------------|-----|
| 1 | DM10294A | FKM FACE SEAL | 1 |
| 1 | DM10295A | EPDM FACE SEAL | 1 |
| 1 | DM10296 | KALREZ® FACE SEAL | 1 |
| 2 | DM100PL | POLY PLUG | 1 |
| KIT | DM102SSV | FKM REPAIR KIT | 1 |

1½" FULL PORT STAINLESS STEEL DRY-MATES



DM150ASS



DM150DSS

1½" FULL PORT STAINLESS STEEL DRY-MATE

| PART NO | DESCRIPTION | MAX PSI | PIPE SIZE | OPENING THRU BALL | QTY |
|-----------|------------------------------------|---------|-----------|-------------------|-----|
| DM150ASS | 1½" MALE X FPT NPT W/ PTFE SEALS | 150 | 1½" | 1½" | 1 |
| DM150ABSS | 1½" MALE X FPT BSP W/ PTFE SEALS | 150 | 1½" | 1½" | 1 |
| DM150DSS | 1½" FEMALE X FPT NPT W/ FKM SEALS | 150 | 1½" | 1½" | 1 |
| DM150DSSE | 1½" FEMALE X FPT NPT W/ EPDM SEALS | 150 | 1½" | 1½" | 1 |
| DM150DBSS | 1½" FEMALE X FPT BSP W/ FKM SEALS | 150 | 1½" | 1½" | 1 |



REPAIR KIT INCLUDES:

- Ball
- Body gasket
- Thrust washer
- Ball seats
- Upper stem bushing
- Stem o-ring
- Face seal

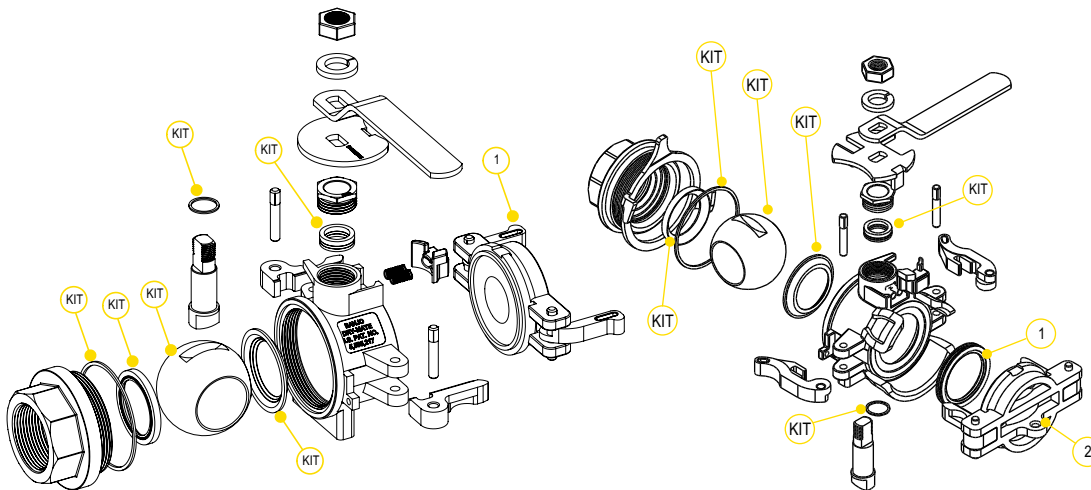

REPLACEMENT PARTS MALE

| ITEM | PART NO | DESCRIPTION | QTY |
|------|-----------|-------------|-----|
| 1 | DM200ACAP | DUST CAP | 1 |
| KIT | DM201SS | REPAIR KIT | 1 |

REPLACEMENT PARTS FEMALE

| ITEM | PART NO | DESCRIPTION | QTY |
|------|----------|-------------------|-----|
| 1 | DM20294A | FKM FACE SEAL | 1 |
| 1 | DB20295 | EPDM FACE SEAL | 1 |
| 1 | DM20296 | KALREZ® FACE SEAL | 1 |
| 2 | DM200APL | DUST PLUG | 1 |
| KIT | DM202SSV | FKM REPAIR KIT | 1 |

DRY-MATES

2" STAINLESS STEEL DRY-MATES

FEATURES

- 316 stainless steel construction
- Patented double ball design with cam lever connection
- 300°F maximum operating temperature
- 100% PTFE ball seats
- When properly installed and operated, the assembly will not accidentally separate while fluid is flowing; preventing costly mishaps
- Spillage data: 2" = 3.6ml



DM200ASS



DM200DSS

2" STANDARD PORT STAINLESS STEEL DRY-MATE

| PART NO | DESCRIPTION | MAX PSI | PIPE SIZE | OPENING THRU BALL | QTY |
|-----------|--------------------------------------|---------|-----------|-------------------|-----|
| DM200ASS | 2" MALE X FPT NPT W/ PTFE SEALS | 150 | 2" | 1½" | 1 |
| DM200ABSS | 2" MALE X FPT BSP W/ PTFE SEALS | 150 | 2" | 1½" | 1 |
| DM200DSS | 2" FEMALE X FPT NPT W/ FKM SEALS | 150 | 2" | 1½" | 1 |
| DM200DSST | 2" FEMALE X FPT NPT W/ KALREZ® SEALS | 150 | 2" | 1½" | 1 |
| DM200DBSS | 2" FEMALE X FPT BSP W/ FKM SEALS | 150 | 2" | 1½" | 1 |



REPAIR KIT INCLUDES:

- Ball
- Body gasket
- Thrust washer
- Ball seats
- Upper stem bushing
- Stem o-ring
- Face seal

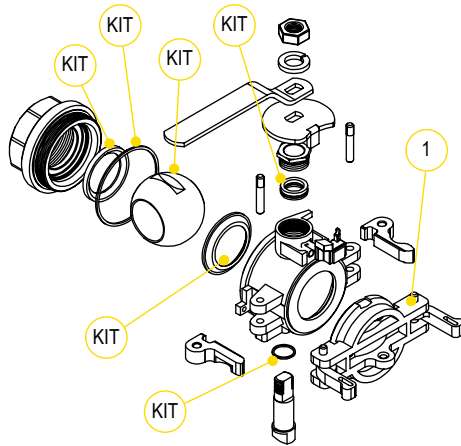

REPLACEMENT PARTS MALE

| ITEM | PART NO | DESCRIPTION | QTY |
|------|-----------|-------------|-----|
| 1 | DM200ACAP | DUST CAP | 1 |
| KIT | DM201SS | REPAIR KIT | 1 |

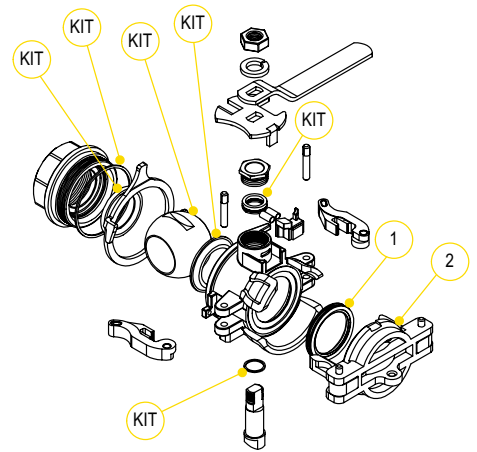

REPLACEMENT PARTS FEMALE

| ITEM | PART NO | DESCRIPTION | QTY |
|------|----------|-------------------|-----|
| 1 | DM20294A | FKM FACE SEAL | 1 |
| 1 | DB20295 | EPDM FACE SEAL | 1 |
| 1 | DM20296 | KALREZ® FACE SEAL | 1 |
| 2 | DM200APL | POLY PLUG | 1 |
| KIT | DM202SSV | FKM REPAIR KIT | 1 |

2" FULL PORT STAINLESS STEEL DRY-MATES



DM220ABSS



DM220DBSS

2" FULL PORT STAINLESS STEEL DRY-MATE

| PART NO | DESCRIPTION | MAX PSI | PIPE SIZE | OPENING THRU BALL | QTY |
|-----------|--|---------|-----------|-------------------|-----|
| DM220ABSS | 2" FULL PORT MALE X FPT BSP W/ PTFE SEALS | 300 | 2" | 2" | 1 |
| DM220DBSS | 2" FULL PORT FEMALE X FPT BSP W/ FKM SEALS | 300 | 2" | 2" | 1 |

FEATURES

- 316 stainless steel construction
- Unrestricted 2" flow
- Patented double ball design with cam lever connection
- 300°F maximum operating temperature
- 100% PTFE ball seats
- When properly installed and operated, the assembly will not accidentally separate while fluid is flowing; preventing costly mishaps
- Spillage data: 2" FP = 3.8ml



REPAIR KIT INCLUDES:

- Body gasket
- Thrust washer
- Ball seats
- Upper stem bushing
- Stem o-ring

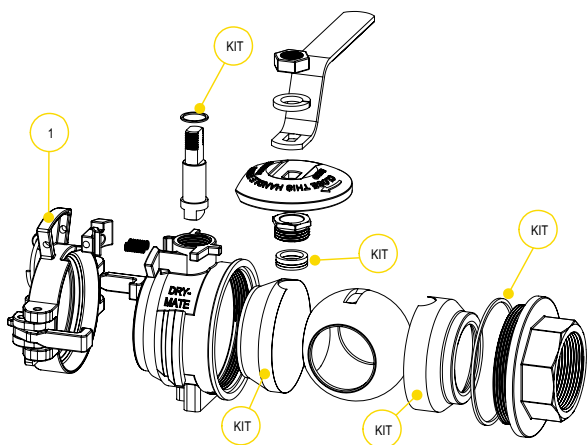

REPLACEMENT PARTS MALE

| ITEM | PART NO | DESCRIPTION | QTY |
|------|----------|-------------|-----|
| 1 | DM220CAP | DUST CAP | 1 |
| KIT | DM221SS | REPAIR KIT | 1 |

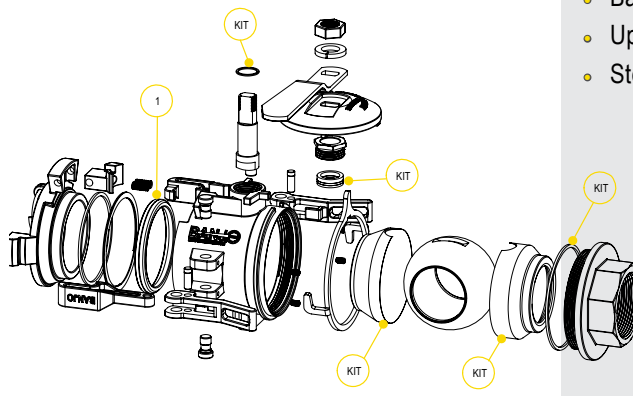

REPLACEMENT PARTS FEMALE

| ITEM | PART NO | DESCRIPTION | QTY |
|------|----------|-------------------|-----|
| 1 | DM25294 | FKM FACE SEAL | 1 |
| 1 | DM25294T | KALREZ® FACE SEAL | 1 |
| KIT | DM222SS | REPAIR KIT | 1 |

DRY POPPET COUPLINGS

FEATURES

- Lightweight
- Minimal fluid spillage
- Easy to use
- Economical
- Reduces risk of exposure
- Wide range of chemical resistance
- Maximum operating temperature 150° F
- 30 GPM maximum flow
- Precision molded in polypropylene
- 1" female NPT threads

APPLICATIONS

- Agriculture
- Industrial
- Pharmaceutical
- Chemical processing

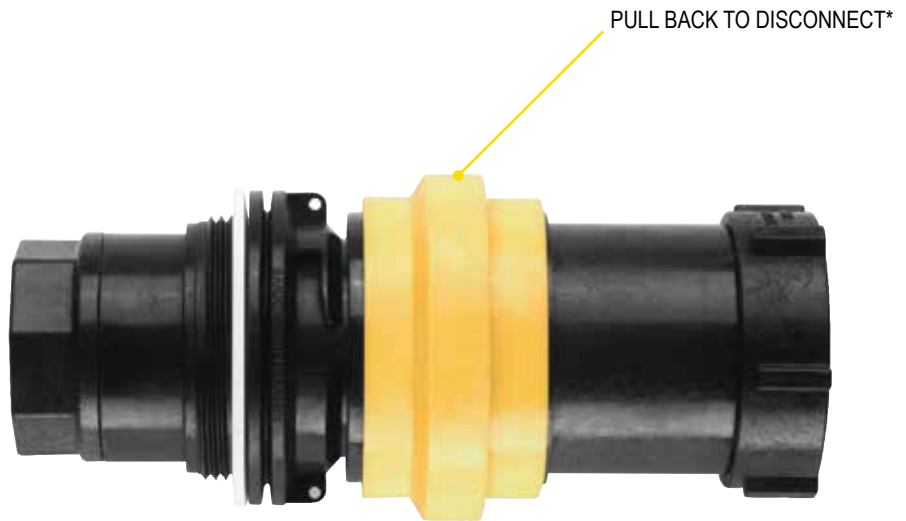

DRY POPPET COUPLINGS

| PART NO | DESCRIPTION | MAX PSI | QTY |
|----------|---|---------|-----|
| DPCF100 | FEMALE DRY POPPET COUPLER, 1" FEMALE NPT THREADS W/ FKM SEALS | 100 | 1 |
| DPCM100 | MALE DRY POPPET ADAPTER, 1" FEMALE NPT THREADS W/ FKM SEALS | 150 | 1 |
| DPCMT100 | MALE DRY POPPET ADAPTER, W/2" MALE THREADED BODY 1" FEMALE NPT THREADS W/ FKM SEALS | 150 | 1 |

***Note:** Male adapter and female coupler shown coupled together but sold separately.